

# CARAVAN TYRES & WHEELS

This leaflet is prepared by The Caravan Club as part of its free service to members. The contents are believed correct at the time of publication, but the current position may be checked with the Club's Information Department.

January 2007

## Contents

Introduction: About Caravan Wheels and Tyres.....	2
Wheels and Tyres on New Caravans.....	3
Wheels and Tyres on Secondhand Caravans.....	4
When to Replace Caravan Tyres.....	4
General Care of Tyres and Wheels .....	5
Tyres.....	5
Wheels.....	6
Miscellaneous Issues .....	7
Wheel Balancing .....	7
Well Fillers.....	7
Tyre Valves .....	7
Inner Tubes.....	7
Tyre Sealants .....	8
Appendix 1: Tyre Sizes and Specifications .....	9
Size.....	9
Load index.....	10
Speed Symbol.....	11
Appendix 2: Tyre Markings .....	12
Tread Wear Indicators.....	12
Overseas Marking Requirements .....	13
North American Department of Transport (DOT) Tyre Identification Number.....	13
Old Form Tyre Size Designation .....	13
EEC Type Approval Mark and Number .....	13
Appendix 3: Choosing the Correct Specification of Caravan Tyre .....	14
Appendix 4: Identifying the Correct Inflation Pressure.....	16
Appendix 5: Wheel Refitting .....	17
Appendix 6: Useful Tools .....	18
Tyre Pressure Gauges.....	18
Tyre Tread Gauge.....	18
Pumps.....	18
Torque Wrench.....	18
Appendix 7: Buying Caravan Wheels and Tyres .....	19
Appendix 8: Alloy Wheels.....	19
Appendix 9: Tyres and the Law .....	19
Appendix 10: Travelling Overseas.....	19
Appendix 11: Contact Details .....	20

## Introduction: About Caravan Wheels and Tyres

There are many fallacies surrounding caravan wheels and tyres, and even credible sources of advice, such as caravan manufacturers and tyre fitters seem to regularly make errors, or at least fail to give comprehensive guidance. The leaflet attempts to address some of these issues, based on The Club's long experience of dealing with such advice. Firstly, some basics:-



### *What are caravan wheels and tyres?*

Caravan wheels may look similar to car ones, but they are usually specially made for caravan use. Principally, this means they are stronger than a car wheel of similar size, although it may also mean that some of the wheel dimensions are different. On a single axle caravan, it's clear that each wheel has to support about half the weight of the caravan, which is often more than one quarter of the weight of a typical car. The relative simplicity of caravan suspension also means that while travelling along, it's possible for much more than half the weight of the caravan to be borne by the wheel(s) on one side from time to time. It's important, therefore, to consider carefully any change in wheel specification for your caravan. As a general rule, it's not a good idea to use car wheels on a caravan, unless you can establish (usually from the wheel manufacturer or supplier) that they are appropriate.

Tyres, however, are not specially made for caravan use. Caravans use either tyres made for cars, or ones designed for use on small vans. While there are tyres designed specifically for use on trailers, these are only available in specifications which suit models like small camping trailers, for instance, or one or two specialist types of larger commercial trailer. All caravans use car or light van tyres.



It's best if your caravan tyre doesn't end up like this....

### *What do caravan tyres do?*

Surprisingly, perhaps, caravan tyres do their job in a different way to car tyres, and need to be treated differently, as a result. On a car, the tyre's traction (if it's on a driven wheel) is important, but caravan wheels are not powered. All the wheels on a car, but especially the front ones while steering need tyres which grip well particularly on wet or slippery surfaces – this is much less important on a caravan (although not entirely irrelevant, of course). Car tyres need to cope with higher cornering forces than are ever likely to be seen by a caravan, too. Also, if

your car tyres generate lots of road noise, you'll be aware of it, whereas on your caravan you won't. Cars tend to have much softer, more compliant suspension than caravans, and have sophisticated shock absorbing. Most caravans have simple, relatively basic suspension, with relatively little inherent shock absorbing characteristics (whether or not the caravan is fitted with separate shock absorbers). In practice, therefore, caravan tyres

tend to provide a significant proportion of the shock absorbing capacity of the suspension, making their characteristics and crucially their inflation pressure particularly important. In essence, the harder you pump up your caravan tyres, the stiffer you are making your shock absorbers. Caravans do a fairly low annual mileage – on average around 2000 miles a year, so it would take many years of use to wear out the tread. However, two or three factors make them deteriorate in a different way, even with careful use. All tyres age and deteriorate due to exposure to sunlight and atmosphere, even if not used. Caravan tyres can suffer fatigue due to the repetitive small impacts they suffer in everyday use, without the protection afforded by the more sophisticated suspension found on cars. Also, being stored for long periods of the year without use can put undue strain on one particular part of the tyre. For all these reasons, caravan tyres need to be specified with care, used with sensitivity in terms of loading, inflation pressure and speed, and properly cared for when not in use. They also need regular replacement, irrespective of their visual appearance, as detailed below.

### Wheels and Tyres on New Caravans

If you've bought a new caravan, you should be able to assume that the specifications of the wheels and tyres are appropriate. The correct inflation pressure should be indicated in the caravan handbook, and is sometimes marked on the wheelarch for convenience too. It's

No. of berths	4
Internal body length	5.56m/18'2"
Overall length	7.03m/23'2"
Internal body width	2.16m/7'1"
Overall width	2.28m/7'6"
Maximum internal height	1.90m/6'3"
Overall height	2.65m/8'8"
Tyre size and pressures	175 R13 97 (54 psi)

Here's a clear indication of the optimum tyre pressure with the caravan fully loaded

not unknown (although it's not common, thankfully) for the manufacturer to get this advice wrong, however, so it would be prudent to double check what the optimum pressure ought to be (see Appendix 4). More common is to find that the tyres are not set to the correct pressure on delivery. Don't assume that the manufacturer and/or the dealer will have checked this.

Many new caravans come equipped with a spare wheel, but this is not a legal requirement. If you get one as standard, it should be the same or equivalent specification of wheel and tyre as the others. If you need to buy a spare separately, make sure both the wheel and tyre are suitable, and compatible with the original ones. The Club strongly advises carrying a spare wheel and tyre, but if considering taking your chances without one, find out first how readily obtainable replacement tyres in the size and specification you need are. Some tyres used on caravans are not held in stock by most tyre fitters, and waiting several days for a non-stock tyre to be delivered could severely disrupt your holiday.

You might reasonably assume that the tyres on a new caravan are recently made. However, caravan manufacturers tend to buy tyres in bulk, and it may take them some time to use up their stock. Hence, your new caravan may have tyres fitted which were themselves made a year ago. (See Appendix 2 for how to identify the age of tyres.) Is this a problem? Unfortunately, there's no simple answer to that question. If the tyres have been stored in suitable conditions of temperature, humidity, light etc, then they should not deteriorate. Whether this has been the case is impossible to judge, however, and arguably, it's wise to deduct this storage time from the expected life of the tyres. Certainly, any time the caravan has been stored awaiting sale or delivery should be counted as time during which the tyres will have started to age.

## Wheels and Tyres on Secondhand Caravans

You're unlikely to know the history of a secondhand caravan, at least in terms of issues such as how much care the previous owner took of the tyres. Assume the worst, and look for signs of abuse and wear and tear. Some people prefer to take no chances and factor in the cost of replacing all the tyres on a secondhand purchase as a matter of course, and this is worth considering. It's good practice to assume the previous owner may have set the tyre pressures incorrectly, so expect to check what the optimum should be and adjust to it. You may not get a handbook with a secondhand caravan, so it may be necessary to work out what the optimum should be from the weight of the caravan and the size of the tyres fitted. Check that any spare wheel and tyre included with the caravan is appropriate, in terms of specification and condition.



“Loads of tread left on those, Guv. Hardly been used since new...”

Very importantly, though, check the age of the tyres. (See Appendix 2.) Even if visually good, and if the caravan has seen careful use over modest mileage, you may still need to replace the tyres due to their age alone. Particularly on older caravans, the tyre specification may need to be upgraded (see Appendix 3), either to allow use overseas (see Appendix 10), or simply because the original type of tyre is no longer available.

## When to Replace Caravan Tyres

It should go without saying that tyres which are damaged or worn to the legal minimum tread depth must be replaced immediately. However, tyres which are visually OK, and which have seen little or even no use are also recommended to be replaced when they reach a few years of age. As a general rule (and following guidance issued by the tyre makers' trade body, the British Tyre Manufacturers' Association, it's advised that caravan tyres should ideally be replaced when 5 years old, and should never be used when more than 7 years old. This advice is borne out by the Club's own research into caravan tyre failures, which confirms that the likelihood of a tyre problem increases after such age. Our research further suggests that tyres which need a high inflation pressure (say 50psi or more) require greater care still. Such tyres should be closely examined for signs of deterioration from 3 years old, and it would be strongly advised not to use them beyond 5 years old. It is not the case that all tyres over these ages will rapidly fail. However, the statistical likelihood of a problem occurring increases noticeably with age. Given the disruption to your holiday that a tyre failure could cause (let alone the risk involved), it's strongly recommended that you follow this guidance.

Since tyres deteriorate with age even when not in use (unless kept under very strictly controlled conditions of temperature, humidity, light level etc), it is usually necessary to consider a tyre's age from the date it was made, and not from when it was bought or fitted to the caravan. Tyre age can usually be identified from a code on the tyre, as described in Appendix 2.

## General Care of Tyres and Wheels

### Tyres

1. Check inflation pressure regularly (prior to every major journey, and monthly when not in regular use, perhaps).
2. Tyre treads should also be examined regularly and any stones etc removed. Considerable damage can be caused to the tyre casing if objects are left embedded. If any object (eg a nail) has penetrated the tyre casing, get the tyre inspected by a tyre fitter, and repaired or replaced as necessary.
3. Oil, fuel or paint can damage the tyre - remove with detergent as soon as possible.
4. Check tread wear regularly. The UK (and European) legal minimum requirement is a tread depth of 1.6 mm across the central three quarters of the tread breadth around the entire circumference of the tyre. Use a tread wear gauge to check this, but be aware that tread wear to the point where the tyre is illegal is rare on a caravan, since usually the tyres require replacement on age grounds long before this. Major tread wear during the normal life of the tyre may indicate a more serious problem, such as incorrect loading, wrong inflation pressure or even poor wheel alignment.
5. If a blister, rupture, cut or object penetration occurs, the tyre should be immediately replaced by a spare and taken to a tyre fitters, where it can be examined by an expert - replacement is usually recommended, although localised damage may be repairable, depending on exactly where it is on the tyre, and how severe it is. Developing problems can sometimes be detected most easily by running a gloved hand over the surface of the tyre, feeling for any raised or uneven areas. Take great care when doing this, however, since embedded objects, or in severe cases, pieces of the steel reinforcing wires used to give tyres their strength could cut your hand. Use something like a leather gardening glove, and a gentle motion, just touching the surface of the tyre.
6. Establish a routine to check tyre condition each time you check pressures. Don't forget the side of the tyre facing away from you, although to check this surface thoroughly, you will periodically need to remove the wheels from the vehicle.
7. If the caravan is not used for a significant length of time, it is recommended that the wheels and tyres are removed and stored at normal inflation pressure in a cool, dry place and protected from direct sunlight, sources of heat, ozone concentrations and fuel/oil spillages. They can be covered with a natural material (eg. hessian) for protection, but not plastic. If wheels must be left on, rotate them regularly, so that the caravan's weight does not bear on one area of the tyre all the time.
8. Check the condition of the tyre valves – make sure the valve stem is undamaged, and is correctly aligned with the valve aperture in the wheel, and not distorted when the wheel trim (if fitted) is installed.
9. Be sure that all valves have suitable valve caps. Valve caps that have sealing washers offer better protection against dirt and dust.
10. Check the valve is not leaking especially after measuring the inflation pressure. Make sure the valve has closed again correctly - if in doubt, fit a new valve.
11. When checking tyre condition, don't ignore the spare!

## **Wheels**

- 1 Check the rim is clean and free from rust (if it is steel), burrs, cracks and distortions.
- 2 Check that the stud holes are not damaged or elongated, and are clean before fitting the studs.
- 5 Follow a correct procedure for refitting wheels after removal. See Appendix 5.
- 6 Steel wheels can be painted to freshen their appearance after a few years' use, but be careful not to obscure any damage or non-cosmetic deterioration under a layer of paint. Do not get paint on the tyre itself, nor on the mating surface between the wheel and the hub, nor on the stud holes. Alloy wheels can be refurbished by polishing and lacquering, but this is a job best left to professional refinishers.
- 7 Plastic wheel trims on steel rims are notorious for being insecure. To avoid annoying (and potentially dangerous) losses, some owners use plastic cable ties to secure the trim to the wheel. These can be easily cut with a sharp knife or wire cutters if the trim needs to be removed to get access to the wheel fixings. Other owners prefer to remove the wheel trims entirely, and perhaps improve the look of the wheels themselves with a coat of silver paint instead!

## **Miscellaneous Issues**

### **Wheel Balancing**

Caravan wheels may or may not be dynamically balanced. Arguably, precise balancing is not required, since many reasons for doing this on cars (eg comfort, reduced steering vibration) don't apply. Some owners report improved towing, however, and it can't do any harm.

### **Well Fillers**

A well filler (eg Tyron Band), can help retain a tubeless tyre on the rim after a puncture, but cannot be used with inner tubes. Keep the multi-lingual instructions and Allen key in case tyres need to be changed abroad. It is important that Tyron equipped wheels are fitted with safety wheel identification markers (15mm diameter red sticker) on the wheel next to the valve. This is becoming recognised by fitters and warns them not to force the tyre off the rim before realising the Tyron band is fitted. See Appendix 11 for contact details.

### **Remoulds/Retreads**

Remoulds/retreads marked with the relevant European Regulation (ECE Reg 108 or 109) are generally suitable for caravan use..

### **Tyre Valves**

Valves vary in length. Make sure the valve used is correct for the wheel and any trim fitted. Always fit new tubeless valves when new tubeless tyres are fitted.

### **Inner Tubes**

The vast majority of tyres in use today do not require inner tubes, and many wheels and tyres can't be used with them. Fitters sometimes advise fitting tubes to caravan tyres when they are neither necessary nor appropriate. Take specialist advice before any such use.

### **Self Supporting Run Flat Tyres**

The BTMA (British Tyre Manufacturers' Association) advises that SST (Self Supporting Run Flat Tyres Tyres) must only be fitted to vehicles which have a Tyre Pressure Monitoring System (TPMS) as a visual / audible warning to drivers of a deflating tyre. As yet no caravans or trailers are equipped with TPMS systems and hence should not be fitted with SST tyres.

### **Directional Tread Tyres**

Some cars are now fitted with tyres where the tread design is intended to give enhanced performance (mainly wet weather grip) by being optimised for use in one direction of rotation. Enhanced wet weather grip is not really relevant for tyres fitted to a caravan, where cornering and braking loads are relatively low. Hence, there would be no significant benefit in fitting such tyres. If they are used, they must be fitted taking note of the directional arrow on the tyre sidewall. In the event of a directional tyre being used as a spare the "wrong" way around, it should be treated as if it were a temporary use spare and should be replaced (or reversed) as soon as possible.

## **Tyre Sealants**

Sealants applied after a puncture as a short term, 'get you out of trouble' measure may be useful, but note that many caravan tyre punctures result in too much tyre damage to use such products. Tyre fitters may be reluctant to repair tyres which have been filled with sealant.

Pre-puncture sealants, intended to protect against punctures occurring are a different matter. The Club does not recommend the use of these, mainly due to a lack of credible, independent, widely applicable test standards for them. We have reason to believe that the effectiveness of such products can vary greatly, yet we have no reliable means to differentiate which, if any, are acceptable. Furthermore, the BTMA specifically recommends against such products, and the existing British Standard for tyre repair states that sealants cannot be considered to be a permanent repair under the terms of that standard.

## **After a Puncture**

After a puncture, have the opposite side (non-punctured) tyre removed from its wheel and checked inside and out for signs of damage resulting from overloading during the deflation of the punctured tyre. Failure to take this precaution may result in an increased risk of a second tyre deflation within as little as 100-200 miles. For this same reason, it's strongly advised to get a punctured tyre repaired or replaced as soon as possible, in case of further incidents.

## Appendices

These sections give more in-depth information about wheels and tyres and are intended as a reference aid. If you have any doubts over the specification or condition of your caravan wheels and tyres, however, you may need to take professional advice from your caravan dealer or a tyre fitter. The Club can also offer guidance on these matters via the UK Technical Advice and Information section – call us on the number you'll find on your membership card.

### Appendix 1: Tyre Sizes and Specifications

Tyres must be chosen so as to be the correct size, and to have appropriate ratings for load carrying capacity and speed of use. Each tyre has a 'full service description', for example:-

TYRE SIZE			SERVICE CONDITION CHARACTERISTICS	
<b>185/70</b>	<b>R</b>	<b>13</b>	<b>84</b>	<b>H</b>
Nominal Section Width (mm)	Nominal Aspect Ratio (H/S)	Radial	Nominal Rim Diameter	Load Index
				Speed Symbol

### Size

The terminology to specify tyre sizes is described below:-

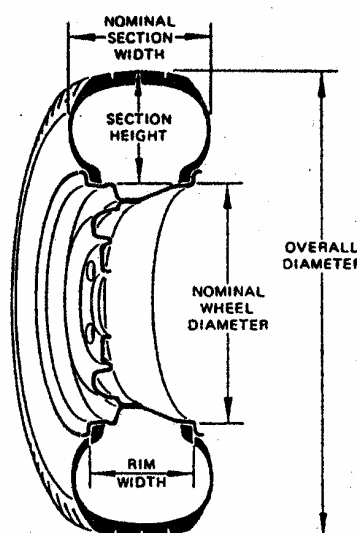

Rim Width      The distance between the inside faces of the rim flanges

The diameter of the rim at the bead seats  
Diameter

The maximum width of the tyre (excluding raised markings, ribs etc.)

The maximum outside diameter of the tyre when fitted and inflated

The distance between the bead seats of the rim and the tyre bead.

The nominal ratio of the section height to the section width, expressed as a percentage.

The rim width of the wheel determines which section widths of tyre can be used on that wheel. Normally a number of different tyre section widths are permissible on a given rim width, but one or two may be recommended as optimum. While it is normally feasible to change to a section width which is one increment different on a given rim (eg 175 instead of 165), this should be confirmed before purchasing. Your tyre fitter should be able to advise on this aspect of wheel/tyre compatibility.

Most caravans have a nominal wheel diameter of 13”, or for more recent models, 14”. It is not usually practical (or necessary) to consider a change in wheel diameter, except possibly if changing from steel to alloy wheels. Larger wheels may give an increased overall diameter for the tyre (unless used in conjunction with lower profile tyres - see below), which can cause problems with clearance within the wheel box of the caravan. It’s also vital to ensure that pattern of fixings used is the same – some larger wheels may have 5 stud fixings instead of 4 stud, making them unsuitable without an expensive change of the caravan hubs as well.

The actual section width and section height of the tyre are determined not only by its nominal size, but also by the width of rim it is fitted to. A relatively wide tyre fitted to a relatively narrow rim will run at a slightly larger overall diameter. This is another reason to check tyre and rim compatibility prior to changing to tyres of a different size – if the dimensions of the replacement tyre are significantly different, it may cause problems with wheel box clearance (above or beside the tyre), or it may prove difficult to get the wheel on and off the hub through the wheelarch aperture.

The aspect ratio is the figure used when describing tyres as ‘low profile’ or not. Lower profile tyres on cars give better roadholding, due to their relatively stiff sidewalls reducing the amount of tyre deformation during cornering. On caravans, however, where the tyres also act significantly as shock absorbers for the caravan, a relatively high profile tyre improves the suspension characteristics, and protects the caravan from damage. Hence, caravans tend to use higher profile tyres than most modern cars.

Heavier duty tyres designed primarily for fitting to light commercial vehicles (ie small trucks and vans) may have a ‘C’ suffix immediately after the nominal wheel diameter figure. This type of tyre is quite commonly fitted to caravans – especially larger single axle ones.

### Load index

The load index is a numerical code which corresponds to the maximum load a tyre can carry at the speed indicated by the Speed Symbol, under specified conditions. The latest recommendation from BRMA specifies that tyres fitted on trailers should not be loaded beyond 90% of the maximum rating of the tyre. The table below shows the load ratings per tyre for different load index values:-

LI	KG	LI	KG	LI	KG	LI	KG	LI	KG	LI	KG
60	250	70	335	80	450	90	600	100	800	110	1060
61	257	71	345	81	462	91	615	101	825	111	1090
62	265	72	355	82	475	92	630	102	850	112	1120
63	272	73	365	83	487	93	650	103	875	113	1150
64	280	74	375	84	500	94	670	104	900	114	1180
65	290	75	387	85	515	95	690	105	925	115	1215
66	300	76	400	86	530	96	710	106	950	116	1250
67	307	77	412	87	545	97	730	107	975	117	1285
68	315	78	425	88	560	98	750	108	1000	118	1320
69	325	79	437	89	580	99	775	109	1030	119	1360

Commercial grade (‘C’ suffix) tyres may show two load index figures - eg 94/92. The lower figure only applies when these tyres are used in a ‘twin wheel’ configuration, such as is sometimes done on the rear axle of larger vans and trucks. Only the higher figure is relevant for caravan use, therefore. Such tyres also often carry the designation ‘6PR’ or

'8PR' at the end of the service description. This stands for '6 Ply Rating' or '8 Ply Rating', and is an alternative indication of load carrying capacity, but doesn't directly relate to a single specific figure.

### **Speed Symbol**

The speed symbol or rating indicates the maximum speed at which the tyre can carry the load indicated by its load index. Speed symbol values are shown in the table below:-

SPEED SYMBOL	SPEED (km/h)	SPEED (mph)
J	100	62
K	110	68
L	120	75
M	130	81
N	140	87
P	150	95
Q	160	100
R	170	105
S	180	113
T	190	118
U	200	125
H	210	130

## Appendix 2: Tyre Markings

The information in the full service description is sufficient to specify tyres for caravan use. Most tyres have a great deal more information marked on them as well, however. Some of this can be useful, while some is irrelevant, or even confusing!

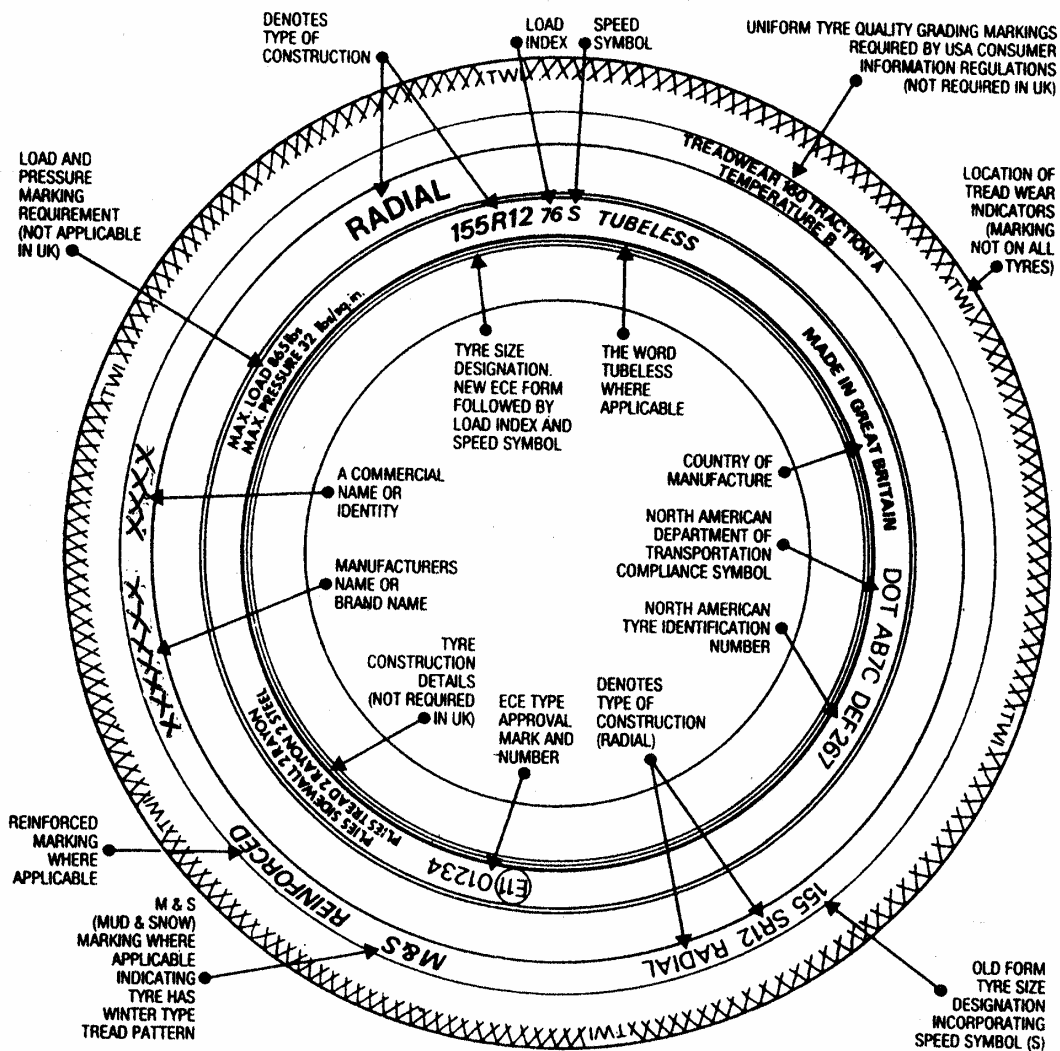

The illustration shows the following tyre:

155 R 12 76 S

155	Nominal section width of tyre in mm
R	Radial Construction
12	Nominal rim diameter in inches
76	Load Index (76 = 400kg per tyre)
S	Speed Symbol (S = 180 km/h or 113 mph)

### Tread Wear Indicators

These markings (if present) show the location of indicators which become exposed when the original tread pattern depth reaches 1.6mm, the legal minimum tread depth permitted.

## **Overseas Marking Requirements**

Most of these markings, relating to maximum loads and pressures, tread wear, traction and temperature values, construction descriptions etc are not applicable in UK or Europe, and generally apply only to the North American market. They are not relevant to UK tyres, and the values quoted are best ignored, since the regulations governing them may not be consistent with European ones, and thus the figures quoted may differ from the relevant European equivalents. The exception to this is the figure discussed in the section below, which indicates when the tyre was manufactured.

### **North American Department of Transport (DOT) Tyre Identification Number**

Example: DEF 267

Prior to the year 2000 the year code was only one digit, eg 267. The last number (7) corresponds to years ending in 7 (eg 1987, 1997). Many manufacturers added a small suffix triangle, eg ‘▲’, to indicate the 1990s rather than preceding decades. From 2000, the week and year of manufacture are clearly stated, eg 0400 (week 4 of the year 2000). Strictly speaking, this information is only required on tyres which are also sold in North America, but many manufacturers include this information on all their tyres.

### **Old Form Tyre Size Designation**

Example: 155 SR 12 RADIAL

Although this marking does not include a load index of 76, the maximum tyre load is still 400kg. Tyres marked in this way are rare now. Check with a tyre supplier for an appropriate modern equivalent. While you shouldn't find this description on any tyres still fitted to a caravan – any such tyres would probably be far too old to still be in use – you may still come across this designation in handbooks for older caravans.

### **EEC Type Approval Mark and Number**

Commonly referred to as an 'E' Number. All radial tyres sold in the UK must now have an E Number on them, except possibly some very high performance tyres which will not be suitable for caravan use. To get an approval number, the tyres must have passed the safety requirements defined by European law, and as such all E-marked tyres can be considered to be of acceptable quality, irrespective of their make or country of origin.

### Appendix 3: Choosing the Correct Specification of Caravan Tyre

As a general rule, replacement caravan tyres should be chosen to be of the same full service description as those previously fitted. However, there are a number of situations where this might not be the case:-

1. The original specification of tyre is no longer available. Since caravans use car or van tyres, they are vulnerable to changes in the mainstream vehicle market resulting in some previously common sizes of tyre becoming obsolete. A good example of this was the 175R13 89R tyre which was commonly fitted to larger cars and larger single axle caravans until a few years ago. As cars and vans have moved to 14" and 15" wheels (or larger) fitted with lower profile tyres, this tyre has become harder and harder to find, and is now effectively obsolete. Owners of caravans fitted with this tyre will probably need to use a light commercial ('C' suffix) tyre instead, and may need to adjust their tyre inflation pressure as a result.
2. The original specification of tyre was inadequate. It is very rare for original equipment tyres to have insufficient load carrying capacity to cope with the maximum weight of the caravan. However, it is more common that manufacturers specify a tyre which is only just capable of such a load, and owners may wish to increase the safety margin when choosing replacements. Another issue with older caravans may be that the original tyres utilised a concept known as the 'bonus load'. It is possible to legitimately 'overload' tyres by 10% as long as they aren't used at a speed above 62mph (100kph). Since caravans are restricted to 60mph in the UK, this is theoretically possible. This practice was quite common at one time, but it causes problems when caravans are taken over the Channel. In France, for instance, it is possible to tow at up to 81mph (130kph) on some motorways, and the French quite reasonably expect your tyres to be capable of this. The use of bonus loads is generally frowned upon now, and is certainly not acceptable if you plan to travel abroad. If your caravan has tyres specified using this principle, they should be upgraded when next replaced, or before any foreign holiday.
3. The payload capacity of the caravan has been increased. Often the caravan chassis and axle etc have spare load carrying capacity, and the limiting factor to safely utilising this may well be the tyres. Always consult with the caravan manufacturer before considering this kind of change, however.
4. The caravan wheels have been changed to ones of a different size (normally the fitting of alloy wheels).

In any of these circumstances, the following checklist should be followed to select an appropriate replacement tyre:-

1. Identify the nominal wheel diameter and maximum caravan weight (normally quoted as Maximum Allowable Weight on older caravans, or Maximum Technically Permissible Laden Mass on newer ones).
2. Select suitable tyres with a full service description to match this wheel diameter, have a load index sufficient for the maximum weight of the caravan (taking into account whether the caravan is a single or double axle), and have a speed symbol of at least 'M' (81mph) or higher.
3. To comply with BTMA recommendations, eliminate any tyre options where the maximum weight of the caravan exceeds 90% of the load index value.

4. If any of the remaining tyres match the section width of the tyres they are replacing, then they should be compatible with no further checks. If the section width differs slightly (eg 185 compared to 175, say) then they are likely to be compatible, unless the clearance between the wheel and the wheel box is particularly small. Try jacking up the caravan wheel to assess the clearance as the wheel moves within the wheel box, if unsure.
5. If the section width differs significantly to that previously fitted, and/or if the rim width has been changed from the original specification, check not only that the tyres are compatible with the wheels, but also that their section width and overall diameter fit within the wheel box. Information on wheel/tyre compatibility should be obtainable from your wheel or tyre supplier. The Club uses the ETRTO (European Tyre and Rim Technical Organisation) reference manual to judge this, and competent wheel and tyre suppliers should have this or equivalent sources of information. ETRTO identify 'permitted' and 'recommended' combinations of tyre and wheel width. The Club advises that only ETRTO 'recommended' tyre/rim combinations are used to minimise problems with issues like wheel box clearance. Much of the necessary information is also listed for common sizes of tyres in the BTMA publication 'Tyre Tips for Caravans and Trailer Tents', which is available free via the contact details at the end of this leaflet.

The table below shows some example data of this type. The 175R13 tyre is a common size fitted to many smaller single axle caravans, with a load index and speed symbol of 86S. The tyre can be used with wheels of rim width 4.5" to 5.5", but the narrower wheel is only 'permitted', not recommended. The nominal section width and overall diameter are 175mm and 610mm respectively, but these will vary slightly depending on the rim width chosen. Unless the 'bonus load' option is applied (not recommended – see section above), this tyre has a load carrying capacity of 530kg per tyre, or 1060kg per axle.

Size Designation			Dimensions		Rim Widths			Maximum Load	
Nominal Section Profile	Type	Nominal wheel Diameter	Section Width	Overall Diameter	Permitted (P) Recomm'd (R)			(Per axle – halve for load per tyre)	
					4.5"	5.0"	5.5"	Without Bonus Load (Recommended)	With Bonus Load (Speed restricted to 62mph – not recommended)
175	R	13	175mm	610mm	P	R	R	1060kg	1166kg

6. Unless also specified by the caravan manufacturer, don't choose an extremely low profile tyre. Most caravan tyres have aspect ratios of at least 65% - anything less than 65% would not be recommended without confirmation of its suitability by the caravan manufacturer. The sample 175R13 86S tyre in the example above has an aspect ratio of 80%, for instance. An aspect ratio less than 80% tends to be referred to as 'low profile', and there is evidence that a lower profile tyre can help with stability due to its greater sideways force capability. However, very low profile tyres (under 65%) might not provide sufficient shock absorbing for the caravan structure.
7. Don't choose a commercial grade ('C' suffix) tyre unless the load and speed requirements demand it, and a 'car type' tyre is not available which can satisfy these. Commercial grade tyres may require a higher inflation pressure (see next section) and can be harder to find replacements for (see section on Travelling Overseas).

## Appendix 4: Identifying the Correct Inflation Pressure

Whether you've just bought new tyres, or simply want to confirm that the inflation pressure of your existing ones is correct, this is an important issue. The safety and durability of tyres depends on their being inflated appropriately. Incorrect inflation pressure can also adversely affect the handling of the caravan, and can increase fuel consumption.

For any given tyre, there will be an optimum pressure it should be inflated to, based on the load it is being asked to carry, and this information can be found on tyre data tables such as those included in the BTMA booklet 'Tyre Tips for Caravans and Trailer Tents'. Since caravans generally operate at or reasonably close to their maximum weight, it's sensible to choose the optimum pressure for that load condition. If you are confident that your caravan is used significantly below its maximum weight, however, you can choose an optimum for its actual laden weight. It's strongly recommend that if you plan to do this, you should confirm the caravan's actual laden weight in its intended loading condition on a weighbridge, and don't rely on an estimated figure.

Using the example of the 175R13 86S from the section above, here is an example of the inflation versus load data you need:-

Size Designation			Inflation Pressure (bar/psi)							
Nominal Section Profile	Type	Nominal wheel Diameter	1.70 25	1.80 26	1.90 28	2.00 29	2.10 30	2.20 32	2.30 33	2.40 35
			Axle Load (kg)							
175	R	13	804	842	898	916	953	989	1025	1060

So for a caravan with a maximum weight of 900kg, the optimum inflation pressure would be 28psi, whereas if the maximum weight is 950kg, the optimum pressure would be 30psi. The three shaded figures indicate axle loads which exceed the BTMA's recommendation of not using tyres beyond 90% of their rated capacity (see sections above).

Choosing the optimum inflation pressure is especially important when using commercial grade tyres. These are designed to operate over a very wide operating range of loads, and thus have a very wide operating range of inflation pressures. A tyre with a maximum inflation pressure of 54psi at its maximum load, for instance, may only require a pressure of 30psi if used on a light caravan. Incorrectly using the maximum inflation pressure on such a caravan (as has been known to be recommended by some caravan manufacturers in their handbooks in the past) would result in the caravan having tyres which are inflated far too hard, giving poor handling, and subjecting the caravan structure and contents to unnecessary vibrations.

## Appendix 5: Wheel Refitting

When wheels have been removed for servicing, or to replace a punctured tyre, it's important that the correct procedure is followed when refitting the wheels:-

1. Ensure that the mating surfaces between the wheel and hub are clean and dry.
2. Ensure wheel nut/stud threads are clean and dry with no rust or paint flakes on the thread or seats. Be cautious of lubricating the threads of wheel nuts or bolts. Tightening torques are usually specified 'dry' and any lubrication may require an alternative torque setting to be used, or damage may result. Check with the caravan or chassis manufacturer for further advice if in doubt about the recommended values.
3. Hand tighten all nuts/studs to centre the wheel before using the wheel brace/torque wrench.

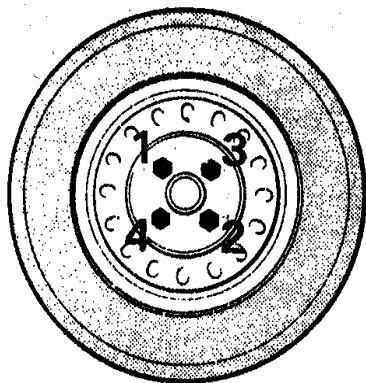

4. Use a wheel nut tightening sequence like that shown to ensure that the wheel seats onto the hub without misalignment.

5. Do not over tighten wheel nuts/studs. Adhere to the tightening torques as recommended by the caravan manufacturer or chassis supplier. These may be different for different makes of wheel, and are generally higher for alloy wheels compared to steel ones. It is not recommended to fully tighten nuts or studs using air-powered equipment. This can over tighten and damage threads. If you suspect that nuts/studs have been over tightened, they should be replaced.
6. The Club recommends you should finish tightening by using a torque wrench set to the figure stated in the caravan operating manual. Do not use the corner steady brace which is only designed to raise or lower the corner steadies.
7. After a wheel has been refitted, always recheck the torque after 20-30 miles use or 20-30 minutes travelling. Even if properly torqued up, it is occasionally possible for fixings to loosen should the wheel 'bed in' on the hub.

*Note: For advice on safely jacking a caravan for wheel removal or refitting, please see the yellow section of your Sites Directory & Handbook.*

## Appendix 6: Useful Tools

### Tyre Pressure Gauges



'Pencil' type gauges are cheap and small, but may be awkward to read, have a limited range (usually no more than 50psi) and limited accuracy and durability.

Digital gauges are also small and cheap, but are easier to read and generally reliable. Accuracy is usually reasonable. Often read to 60psi or more.

Dial gauges are more expensive (but not necessarily by much). Come in a range of sizes (larger ones being easier to read). Most likely to be really accurate, especially if marked with a relevant standard, such as BS 4613. Often read to higher maximum pressures.

### Tyre Tread Gauge



'Pencil' type gauges (left) read in a similar way to pencil pressure gauges. Digital gauges are also available, and are easier to read, but are more expensive.

### Pumps



Traditional foot pumps are simple and cheap, but require significant effort. 12V compressors are not much more expensive, but are much easier to use.

### Torque Wrench



A relatively cheap DIY-type torque wrench should be sufficient.

## **Appendix 7: Buying Caravan Wheels and Tyres**

For wheels, stick to specialist retailers – ie caravan dealers and accessory suppliers, or specialist wheel suppliers (see Appendix 11). Be very sceptical of secondhand wheels, unless certain they are in good condition, and of an appropriate specification.

For tyres, shop around. Prices vary hugely, and any make of tyre which has the correct service description and is Type Approved for use in Europe is acceptable. If buying more than one tyre, get a price initially for just one, and see if a discount (or free valves and fitting etc) is then available if buying more than one. Make sure you know exactly what specification you want, as many retailers are not very knowledgeable about caravan tyres.

## **Appendix 8: Alloy Wheels**

Alloy wheels are available, but it is best to choose those specifically designed for caravans, rather than trying to find car ones with the correct characteristics. Note that the wheel fixing and the fixing torques will almost certainly be different compared to steel wheels.

## **Appendix 9: Tyres and the Law**

It is an offence to mix crossply and radial tyres on the same axle – although cross ply tyres (unless extremely old) are rarely found on caravans now.

It is strongly recommended that aspect ratios are also matched (80 and 82 can be counted as the same), as should ply ratings or load index values on the same axle, although these are not legal requirements. Mixing different makes of the same size or specification is OK.

Tyres must be correctly inflated, and free from certain cuts and other defects. They must have at least 1.6mm tread depth across the central three quarters of the tread breadth around the entire circumference of the tyre. They must be of a suitable specification.

If a spare wheel and tyre is carried, it must also comply with all relevant regulations.

The maximum fine for each defective or unsuitable tyre is £2500, plus 3 points on the driver's licence.

## **Appendix 10: Travelling Overseas**

As a general rule, if your vehicle meets the legal requirements for use in the UK, then it can be used across Europe without difficulty. An exception to this is the situation relating to tyres in France. Since on certain French motorways it is permissible to tow at up to 81mph (130kph), the French require that your tyres meet this requirement. This is only likely to be a concern with older caravans, but if in any doubt, check the specification of your tyres before travelling, since on-the-spot fines can be significant.

The availability of tyres in appropriate sizes also varies from country to country. Certain sizes of tyre commonly used on UK caravans (eg 175R13C, for instance) are not as readily available. It is prudent to carry a spare anyway, of course, but many owners take a second spare tyre if travelling long distances. Even The Club's Emergency Service cannot always source suitable tyres locally, and regularly has to ship tyres by courier to members. Double check your tyres' condition and age before travelling.

## Appendix 11: Contact Details

British Tyre Manufacturers' Association (BTMA)  
6 Bath Place  
Rivington Street  
London  
EC2A 3JE

Tel 0207 457 5040  
Fax 0207 972 9008  
Email [mail@btmauk.com](mailto:mail@btmauk.com)  
Web [www.btmauk.com](http://www.btmauk.com)

Tyre industry trade association

Gaslow International Ltd  
Unit 1  
Weldon Road  
Loughborough  
Leics  
LE11 5RA

Tel 0845 4000600  
Fax 0845 4000700  
Email [info@tyron.com](mailto:info@tyron.com)  
Web [www.gaslow.co.uk](http://www.gaslow.co.uk)

Tyron Safety Band

Tyre-Line Original Equipment Ltd  
Cedar House  
Sopwith Way  
Daventry  
Northants  
NN11 5PB

Tel 01327 701000  
Fax 01327 701001  
Email [sales@tyreline.com](mailto:sales@tyreline.com)  
Web [www.tyreline.com](http://www.tyreline.com)  
Wheels (inc alloys) and tyres

Wheel Solutions Ltd  
Unit 2  
Upper Keys Business Park  
Keys Park Road  
Hednesford  
Cannock  
WS12 5GE

Tel 01543 870170  
Fax 01543 870175  
Email [enquiries@wsl.uk.com](mailto:enquiries@wsl.uk.com)  
Web [www.wheel-solutions.co.uk](http://www.wheel-solutions.co.uk)

Wheels and tyres